

SECTION A-A

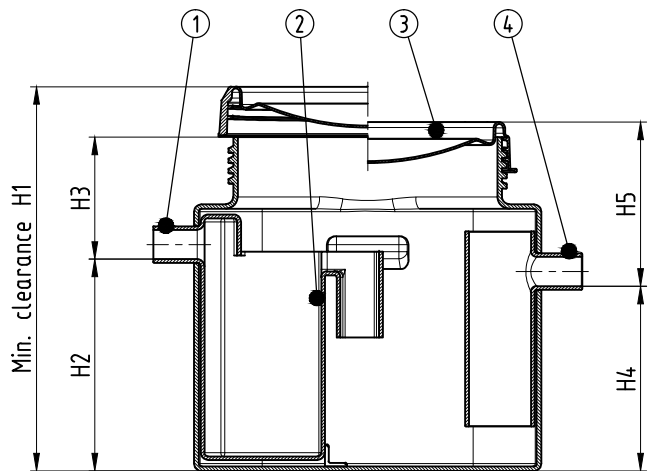

SECTION B-B



Grease sep. in small tank with sludge trap

H1	526
H2	290
H3	167
H4	253
H5	225
D1	φ4,08
D2	φ50
L1	380
L2	587
L3	475

Volume and capacity

	<i>With sludge trap</i>
Nominal size	NS 0.5
Effective volume	50 l
Grease storage capacity	3 l
Effective volume sludge trap	9 l
Max flow rate grease sep.	0.5 l/s

Part list

- 1 Inlet pipe
- 2 Separation box Sludge trap
- 3 Cover with rubber ring
- 4 Outlet pipe

REV.5	REV.6
REV.3	REV.4
REV.1	REV.2

Status:



BELONGS TO DWG
PART OF DWG

AMERICAN PROJECTION

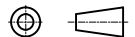

NAME : Grease separator NS0,5

DATE : 1-12-2009

SCALE : UNITS MM

DRAWN : M. Schouten

PIPELIFE CORPORATE R&D, FLEVOLAAN 7 1601 MA ENKHUIZEN, THE NETHERLANDS

DWG NO : 046-011376

A4