

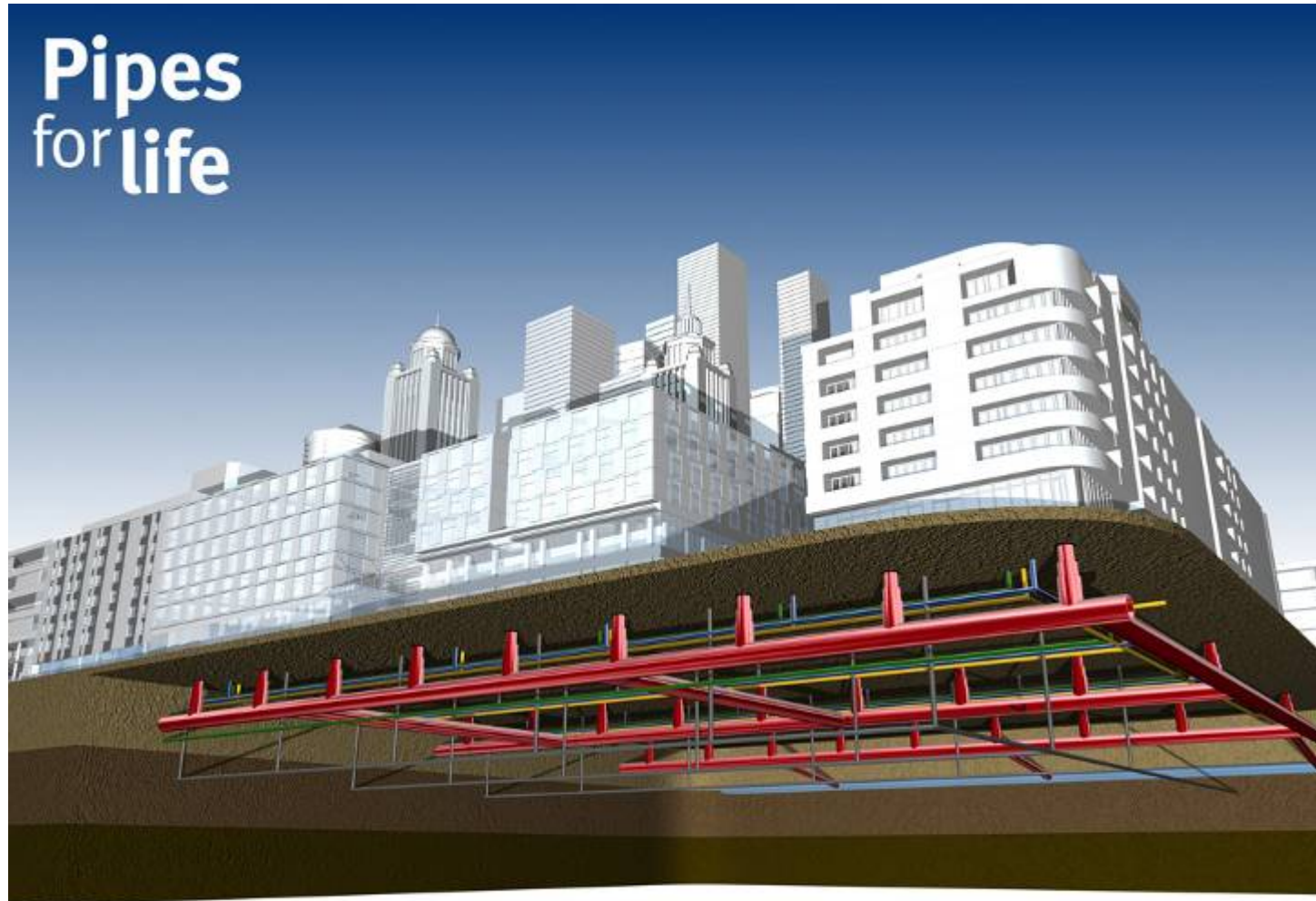

Corporate Group Presentation 2012



Pipelife – Pipes for Life

Net Sales 2011	805 mEUR
Sales Offices	Active in 27 countries
Production Sites	27
Employees (average 2011)	2.651
Headquarters	Vienna, Austria

Net Sales
(mEUR)

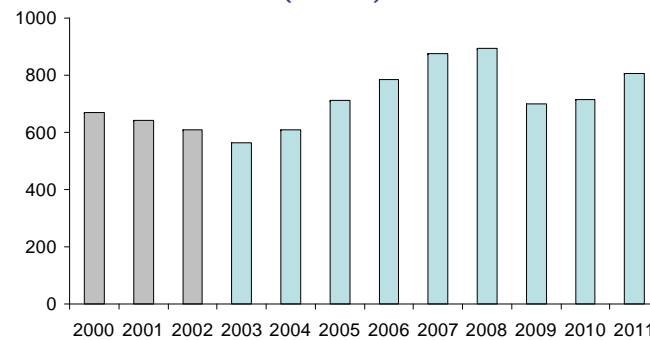

Employees
(average)

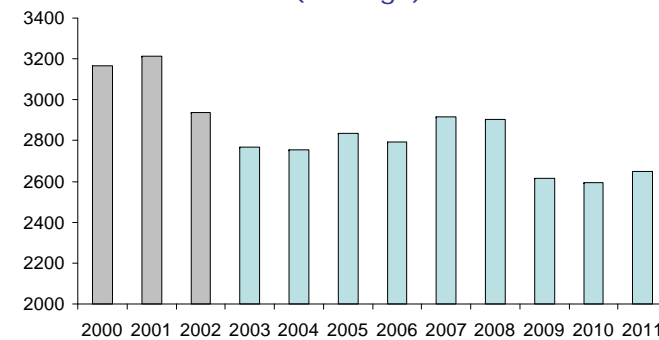

- 1989 Foundation of Pipelife by Solvay & Wienerberger: AT, FR, DE
- 1990 Entering the Hungarian market, Joint Venture with Pannonplast
- 1992 Expansion of business into Greece and Turkey
- 1994 Further business expansion: CZ, SK, SI
Integration of Solvay pipes and fittings activities in BE, ES, NL, PT
- 1996 Start of operations in Poland and Romania
- 1997 Acquisition of Davinyl (SE), business expansion to Croatia
- 1999 Acquisition of the MABO Group: EE, FI, LT, LV, NO
Integration of Wienerberger's pipes activities in China
- 2000 Acquisition of Jetstream (US), opening of sales offices in Russia & the Ukraine
- 2003 Acquisition of 100% Pipelife Czech and Pipelife Slovakia
- 2004 Acquisition of Propipe (FI)
Acquisition of PVC business of Drossbach (DE)
- 2005 Acquisition of 100% Pannonpipe and Pipelife Romania
Foundation of Pipelife Bulgaria
- 2006 Investment in Pipelife plant in Russia
- 2007 Acquisition of Quality Plastics (IE)
Start of operations in Russia
- 2008 Acquisition of Instaplast (CZ)
- 2009 Investment in Pipelife plant in Bulgaria
- 2010 Acquisition of Westpipe (SE)
Closure of Pipelife subsidiaries in Spain and Portugal
- 2011 Acquisition of Alphacan Pipe Business (FR)



Leadership Principles



inspire

- * We create an atmosphere of optimism, enthusiasm and opportunities
- * We encourage creativity, innovation and initiative
- * We are visionary with our goals, open to challenges and supportive of change
- * We establish an atmosphere of trust and tolerance

commit

- ✓ We identify with the Pipelife Mission, Vision and Value statements
- ✓ We agree on and communicate clear targets
- ✓ We direct our actions towards the achievement of local and group objectives
- ✓ We set example with our behavior and encourage our people to follow by being honest, loyal and acting according to the highest ethical values
- ✓ We give the best of ourselves and energize others

empower!

- ! We coach, support and develop our teams
- ! We delegate authority and responsibility
- ! We listen actively and communicate openly
- ! We make resources and necessary tools available
- ! We recognize, reward and stand by our people

deliver

- ! We ensure the development of efficient processes
- ! We remain focused on our targets and work according to priorities
- ! We measure, correct, support and achieve
- ! We ask for and give feedback, learn from our mistakes and continuously develop

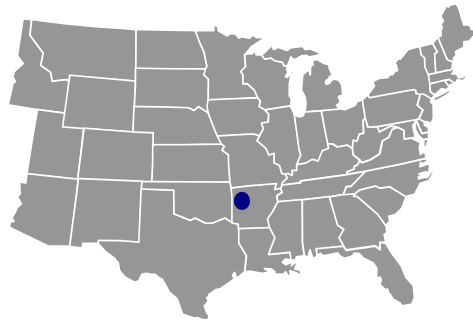

Region US

Region West & North

Region Central Eastern Europe (CE)

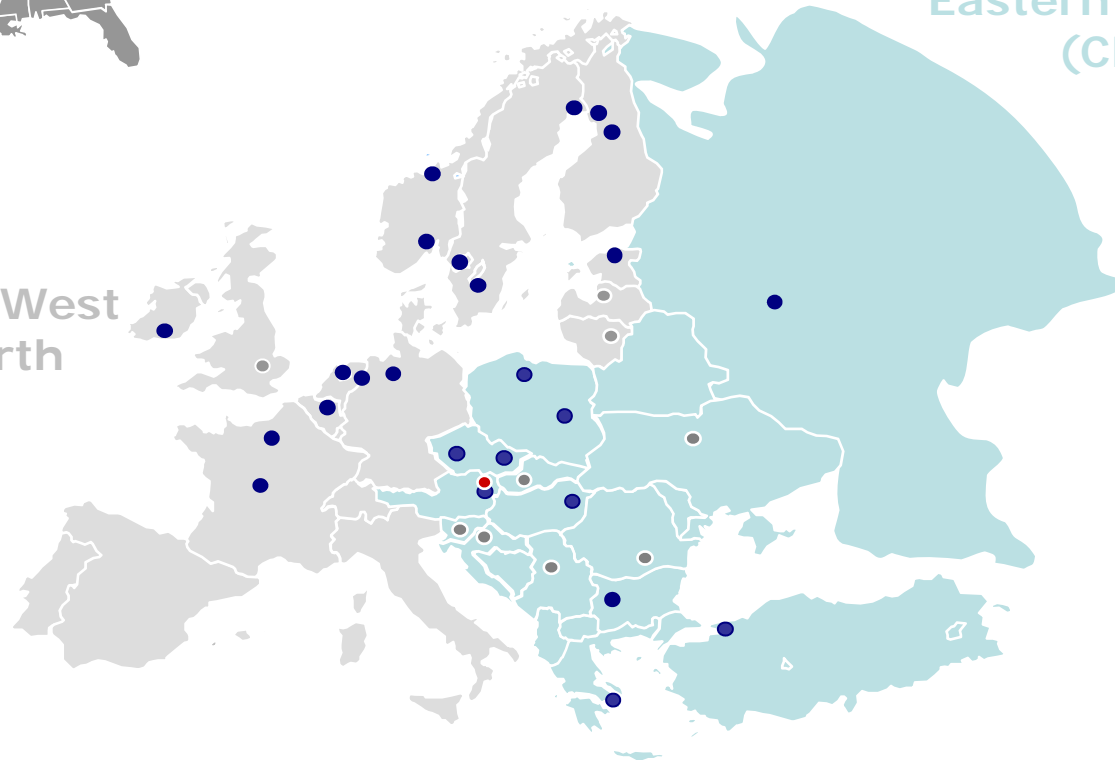

- Plant
- Sales Office
- Headquarters

Mission

“Improve quality of life by providing high value solutions for the protection and flow of water and energy.”

Vision

“The Number ONE value creator in our markets”

Values

- Go the last mile for the customers
- Invest in quality of people first
- Run lean and un-bureaucratic
- Focus on innovation and speed
- Improve performance every single day
- Act honestly, with integrity and citizenship
- Work hard, oriented to results, yet have fun





Electro and Cable & Gas

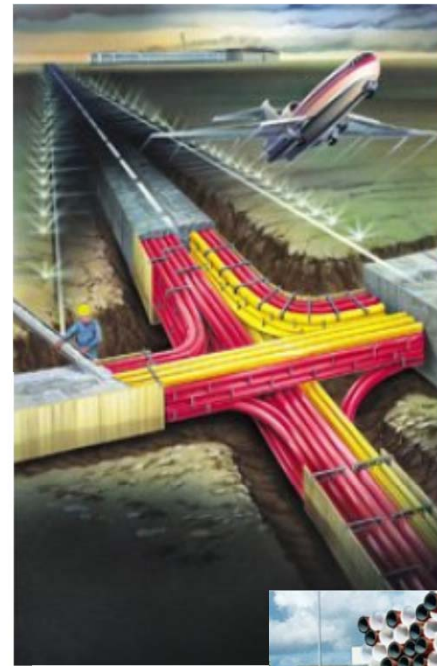

Specialties
Industrial & Environmental

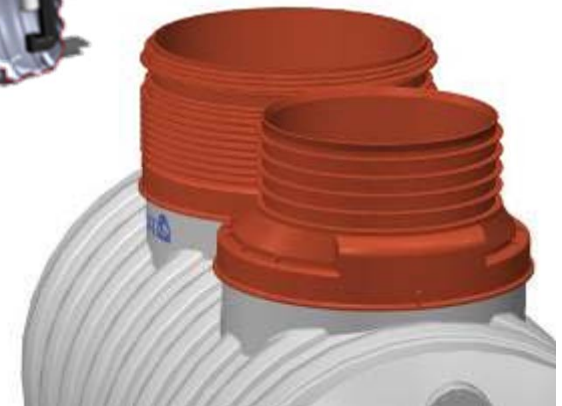
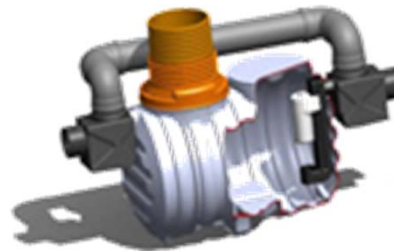

Extrusion / Injection Molding / Roto-Molding / Assembling

