

INSTALLATION GUIDELINES

SIPHONIC OUTLETS AND DRAINAGE PIPE SYSTEMS
FOR FLAT AND LOW-GRADIENT ROOFS





CONTENTS

SYSTEM INFORMATION	4
APPLICATION AREAS	4
INSTALLATION INSTRUCTIONS	8
PIPE AND FITTING CONNECTION METHODS	12
BUTT-WELDING	13
ELECTRO-FUSION WELDING	15
FIRE SAFETY	16
TRANSPORT, STORAGE AND HANDLING	17
SYSTEM DESIGN SERVICE	18

SYSTEM INFORMATION

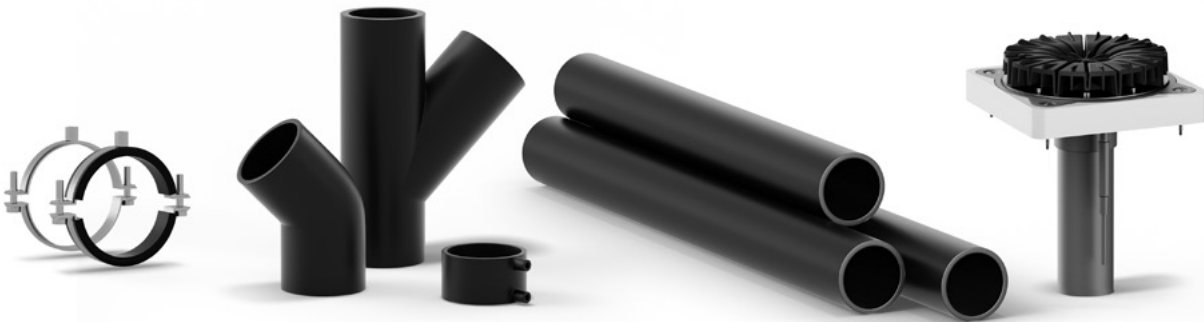

PIPELIFE siphonic roof drainage systems utilize negative pressure to evacuate rainwater with high flow rates. The siphonic mechanism keeps air out to produce a closed water column during drainage. Compared to gravity systems, this ensures a much higher flow velocity through smaller pipe diameters for fast and efficient drainage.

During periods of high precipitation, the siphonic apparatus draws rainwater into the downpipe at a flow rate of up to 20 l/s.* This exceeds standard siphonic drainage flow rates by up to 60% and is more than twice the flow rate of a traditional gravity system. As a result, PIPELIFE siphonic systems require far fewer outlets, downpipes and underground network connections than conventional setups.

APPLICATION AREAS

PIPELIFE's siphonic solution offers high-capacity drainage for flat roofs of up to 3% incline and a minimum area of 150 m².

An effective choice for:

FACTORIES
WAREHOUSES
AIRPORTS
SHOPPING MALLS
CONVENTION CENTERS
APARTMENT BLOCKS
HOTELS
OFFICE BUILDINGS

Compatible with a diverse range of roof types:

COLD
INSULATED
INVERTED
GREEN



**STANDARDS RELATED
TO DESIGN AND
CONSTRUCTION**

VDI 3806
DIN 1986-100

*DN75, 55 mm head of water

The diameters, wall thicknesses and tolerances of PIPELIFE siphonic system pipes are indicated in the following table. These values are compliant with the currently used **UNI EN 1519-1:2019 standard**.

Nominal diameter DN (mm)	External diameter OD (mm)	Minimum and maximum external diameter (mm)		Wall thickness and tolerance (mm)		Series S	SDR
32	32	32	32.3	3	+0.5 0	S 8.3	17.6
40	40	40	40.4	3	+0.5 0		
50	50	50	50.5	3	+0.5 0		
56	56	56	56.5	3	+0.5 0	S 10	21
63	63	63	63.6	3	+0.5 0		
75	75	75.5	75.7	3	+0.5 0	S 12.5	26
90	90	90	90.9	3.5	+0.6 0		
110	110	110	111	4.2	+0.7 0		
125	125	125	126.2	4.8	+0.7 0		
160	160	160	161.5	6.2	+0.9 0		
200	200	200	201.8	6.2	+1.0 0	S16	33
250	250	250	252.3	7.7	+1.0 0		
315	315	315.2	317.9	9.7	+1.2 0		

FIXING TECHNOLOGY

The system that supports the siphonic pipework consists of the following elements:

1. Mounting rail
2. Clamp bracket
3. Threaded rod
4. Rail connection piece
5. Trapezoidal sheet hanger
6. Sliding point pipe clamp (SP)
7. Fix point pipe clamp (FP)

The minimum distance between mount points (X) depends on the diameter of the pipe.

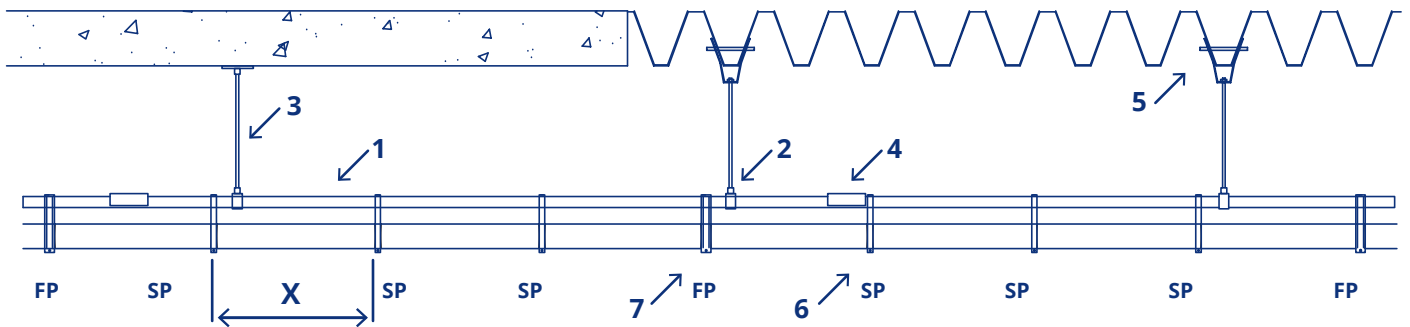

Exposed horizontal pipe sections must be suspended by the support system. This system can absorb pipe elongations caused by fluctuations in temperature and consists of a C-profile rail system made from zinc-coated steel with precalculated fix points and sliding elements. It has been designed to reduce the number of suspension points, allowing for longer bridgeable distances. After preassembly on the ground level, the completed modules can be connected beneath the ceiling.

Similarly to gravity systems, vertical sections are secured to the building structure using pipe clips. The system incorporates expansion sockets (compensators) between the fix points to accommodate downpipe heat expansion.

The installer must ensure that the end of the pipe's guided portion does not reach the bottom of the expansion socket.

APPLICATION OF THE EXPANSION SOCKET IN A DOWNPIPE:

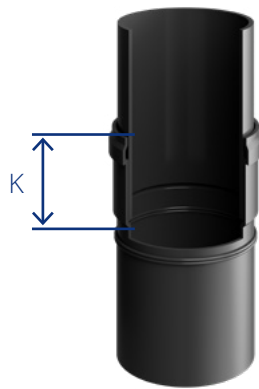
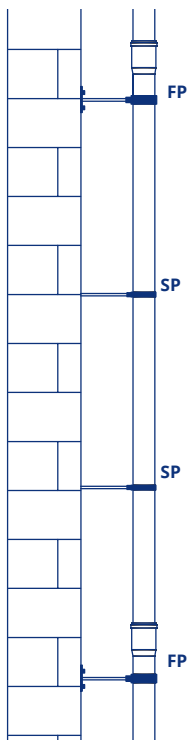

Nominal pipe diameter DN	Maximum distance between mounting points
40	0.8 m
50	0.8 m
56	0.8 m
63	0.8 m
75	0.8 m
90	0.9 m
110	1.1 m
125	1.2 m
160	1.6 m
200	2.0 m
250	2.5 m
315	2.5 m

Penetration depth (K) [mm] of the pipes into the expansion socket can be determined at different assembly temperatures from the table below:

DN	-10 °C	0 °C	+10 °C	+20 °C	+30 °C
40-125	147	135	123	111	99
160	150	138	126	114	102
200	191	179	167	155	143
250	185	173	161	149	137
315	205	193	181	169	157

INSTALLATION INSTRUCTIONS

To ensure full-bore flow, it is essential that the pipes are assembled in accordance with the following guidance. Failure to comply with these guidelines could lead to suboptimal flow rates.

EU standards VDI 3806 and DIN 1986-100 mandate the design specifications and characteristics required for siphonic rainwater drainage systems. Based upon these standards, PIPELIFE has determined the following guidance for design and construction.

Pipe sections that run parallel to the ceiling should be installed in a level, horizontal position. There is no need for pipes to be installed with a gradient:

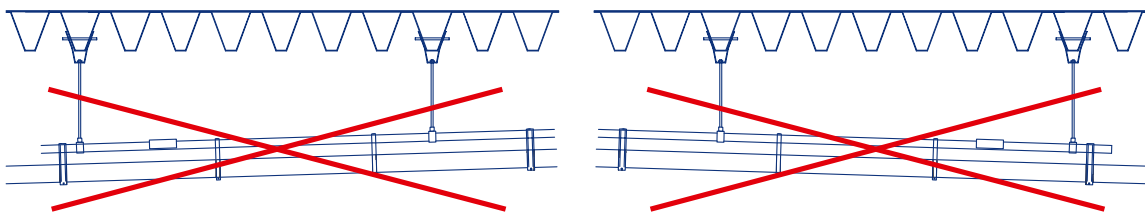
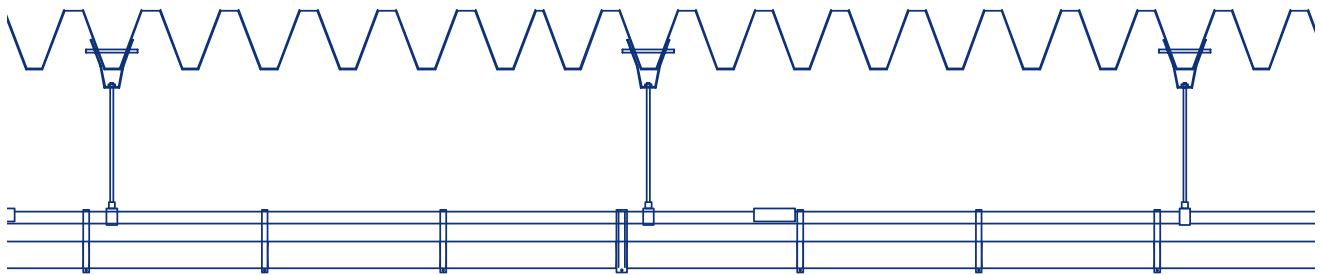

Only use 45° angle bends and branches:

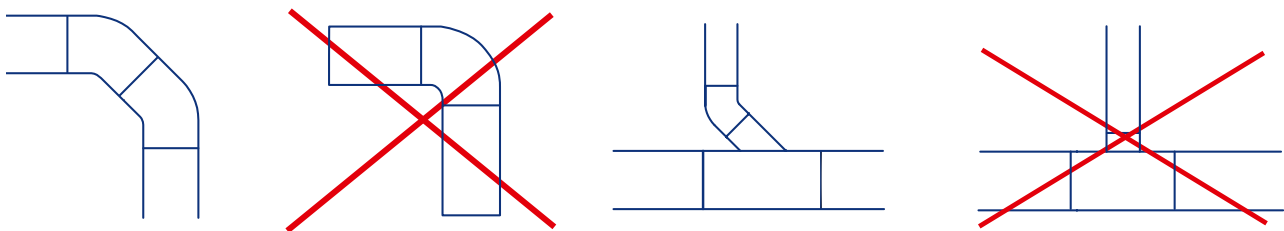

To allow for different flow rates on long pipe sections, PIPELIFE supports the use of pipes with different diameters. Eccentric reducers should be used to connect the different sections.

When using an eccentric reducer, the upper pipe walls must be aligned.

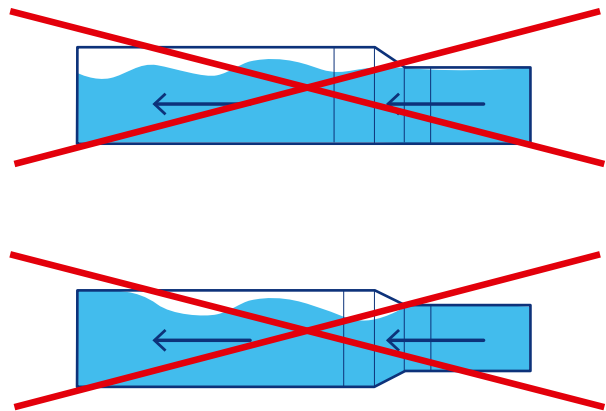

In vertical pipe sections, the eccentric reducers must be installed in a way that ensures the aligned side faces the wall.

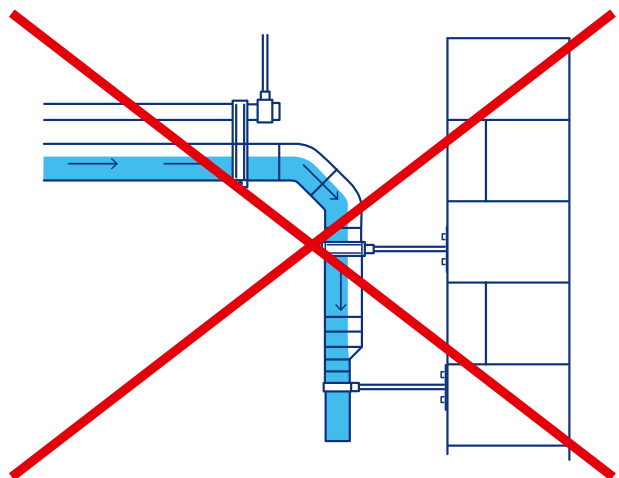
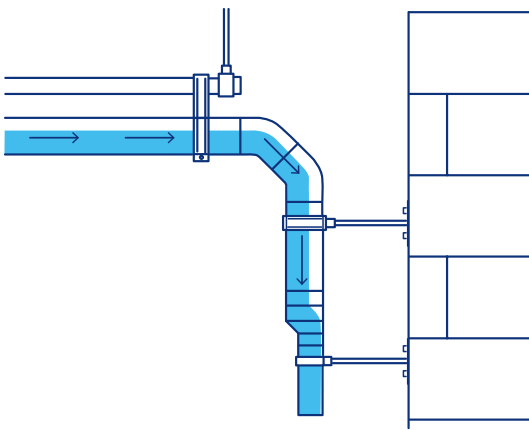

A number of outlets from one roof level can be connected to a singular downpipe.
However, you cannot connect outlets from more than one roof level to the same downpipe.

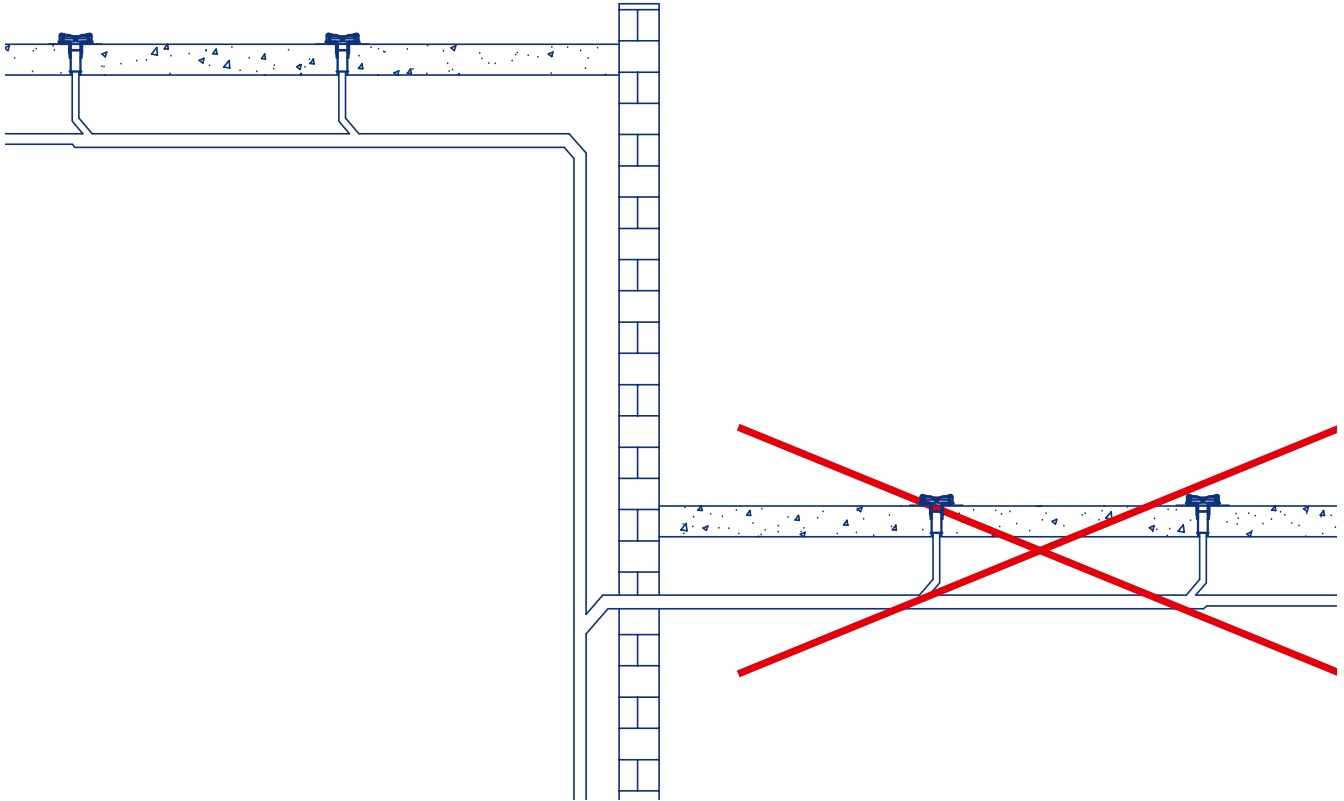

The PIPELIFE siphonic system can only be connected to a gravitational system that has suitable capacity.

The maximum distance between two roof outlets is 20 m.

In case the roof water level exceeds 55 mm, overflows (emergency spillways) should be provided either on a parapet or by utilizing a longer tailpipe below the outlet.

Horizontal connecting pipes should be at least 60 cm below the roof level.

The optimum ratio for the vertical and horizontal pipe lengths is $L1/L2 = 10:1$.

The permissible load for light construction roofs is 75 kg/m².

Rainwater can be discharged with a single downpipe from roofs of approximately 5000 m².

A minimum of 300 l/s/ha of rainwater is required to trigger the siphonic action.

The optimal volumetric flow rate for the roof outlets is 8–12 l/s.

The system's self-cleaning attributes will start after a minimum flow rate of 0.7 l/s.

The building operator must inspect the outlets at least once a month — cleaning them if necessary.

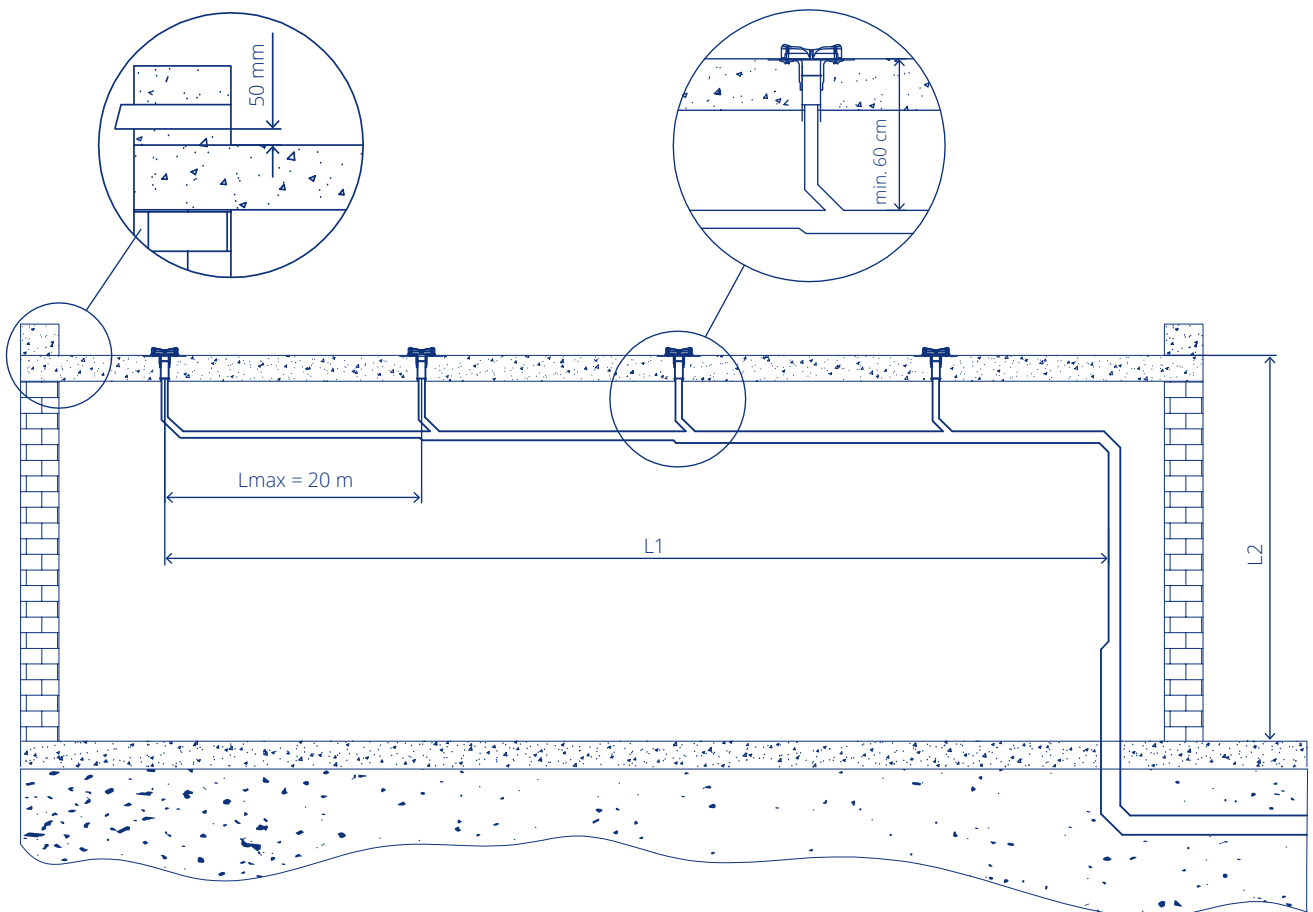

PIPE AND FITTING CONNECTION METHODS

PIPELIFE siphonic system pipes and fittings can be connected with the following methods:

BUTT-WELDING



ELECTRO-FUSION WELDING



BUTT-WELDING

Butt-welding is a popular method for prefabricating pipe connections.

It is not recommended to butt-weld pipes that are already in operation.

Butt-welding consists of two main operations:

First, the joining surfaces should be heated to their melting temperature by pressing the ends of the pipes onto a welding plate.

Then, the two heated surfaces should be united and held in position. This can be done by hand for pipes up to 50 mm in diameter. For larger pipes, a welding machine may be required.

When manually butt-welding, it is recommended to use supports that will keep the pipe ends aligned.

To achieve an adequate butt-welded connection, the following requirements should be met:

- The joining surfaces should be clean and oil-free.
- Both joining surfaces should have the same chemical composition.
- The pipes and/or fittings should have the same diameter and thickness.
- In humid, windy or low-temperature conditions, the welding area should be covered before heating. In these circumstances, welding tests should be carried out in advance.
- The joining surfaces must reach the specified temperature (210 °C) before welding begins.
- Once the welding process begins, the connection should not be subject to any mechanical stress until it has cooled completely.
- When welding large-diameter pipes, it is necessary to align the pipes with the support of a guiding tool.

BUTT-WELDING METHOD STEPS:

1. Cut the pipes perpendicularly along the longitudinal axis with a suitable tool for the diameter.
2. Clean and chamfer the pipe ends.
3. Press the pipe ends onto a welding plate heated to 210 °C (± 5 °C). Hold them on the welding plate until a seam of about 1 mm has formed around the circumference.
4. Remove from the welding plate and connect the pipes on their melted edges as quickly as possible. Engage an axial force without rotating. A guide can be used to keep the pipes aligned.
5. Allow the connection to cool completely. The cooling period should not be assisted artificially (e.g., with cold water).

The quality of butt-welded connections depends on the installer’s knowledge and practice. When butt-welding with an electrical welding machine, the preparatory steps (cutting and chamfering) can also be executed by the machine. Supporting the pipe ends by locking them in position will facilitate a high-quality connection.

When compressing the pipe ends, the force used can be read by the machine — the permissible value of which depends on the diameter of the pipe and can be determined from the compression force table. The necessary compression force must be applied accordingly.

COMPRESSION FORCE TABLE

Nominal pipe diameter DN	Force equivalent in kg
40	6
50	7
56	8
63	9
75	10
90	15
110	22
125	28
140	35
160	45
200	57
250	90
315	140

Heating and welding time depends on the pipe diameter and wall thickness — illustrated below:

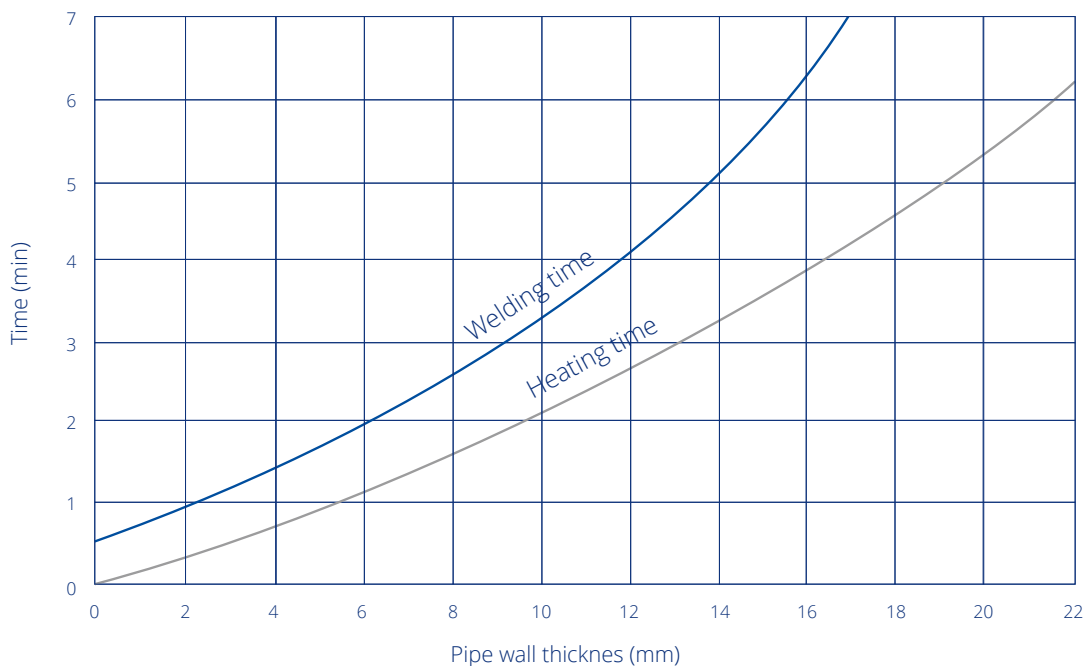

Welding diagram

ELECTRO-FUSION WELDING

This connection method can be used for prefabrication, repairs, or conversions in existing systems. The connection is created by means of an electro-fusion sleeve, which contains heating filaments on the internal surface. The filaments produce thermal energy thanks to an electrical current that runs through them.

The filaments heat the internal surface of the sleeve so that it melts together with the external surface of the pipes. On the internal surface of the electro-fusion sleeve, there is a bar (detent) that can be removed to facilitate deeper insertion of the pipe ends (or used as a double-sliding socket), enabling repair works in an existing system.

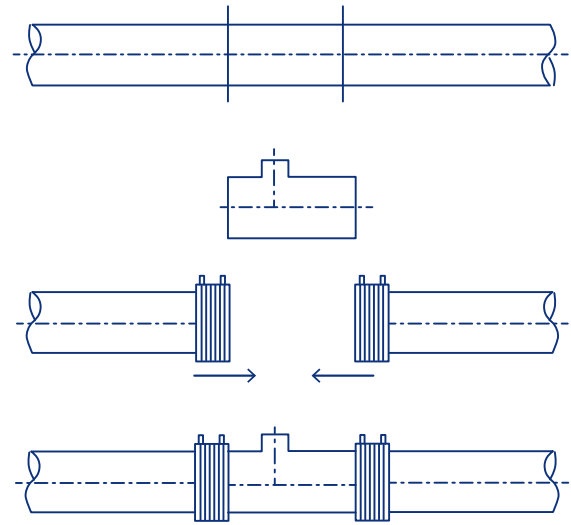

Prior to welding, the pipe ends and electro-fusion sleeve should be at the same temperature as the environment; the connection should not be exposed to direct solar radiation.

- Only PIPELIFE-approved welding machines can be used.
- The pipes should be cut to length immediately before welding, using an appropriate cutting tool. The pipe ends could contract over time, which would lead to inaccurate welding.
- The cut pipe ends must be cleaned and scraped before welding — at least 1 cm longer than the section of the pipe that will be inserted into the sleeve. Failure to scrape, or scraping incorrectly, could prevent the plastic molecules from binding uniformly. Only dedicated scraping tools should be used. The use of an abrasive-coated cloth is prohibited.
- Remove the electro-fusion sleeve from the package just before use and wipe the inner surface with a clean cloth.
- Insert the scrapped pipe ends into the sleeve until they reach the bar and secure with clamps. The parts must not move throughout the process — from the start of welding until the connection has fully cooled.
- Electro-fusion welding can be conducted in ambient temperatures between $-5\text{ }^{\circ}\text{C}$ and $+40\text{ }^{\circ}\text{C}$.
- Due to its significant energy consumption, the welding machine must be connected to an electricity supply of suitable capacity (in accordance with the accompanied operating instructions). Fluctuations in the electrical current could adversely affect the welding quality.
- The welding machine should only be connected to the electricity supply after the pipes have been secured inside the sleeve.
- Once turned on, the machine will start welding and produce an acoustic signal to signify each part of the process. Sleeves with diameters 40–160 mm are equipped with indicators that change color when heated. Once welding has been successfully completed, the indicators will change color from white to black. If welding has been unsuccessful, the electro-fusion sleeve should not be used again.
- Cooling time after welding is determined according to the pipe diameter (between 10 and 30 minutes).

FIRE SAFETY

Fire safety regulations for the PIPELIFE siphonic roof drainage system must be observed at all times. This requires the addition of a suitable firestop sleeve on any pipe work that passes through the building structure (walls, floors, ceilings, etc.).

The firestop sleeves must be placed directly around the pipes. In the event of a fire, the sleeve will expand inwards (at a 1:10 ratio) when it reaches a certain temperature, crushing the pipe. As the pipe is crushed, the sleeve closes off the opening in the wall — preventing flames, smoke and melted particles from passing through the opening. The sleeves are equipped with fastening clasps that enable easy fixation to the building structures.

Types of installation of firestop sleeves

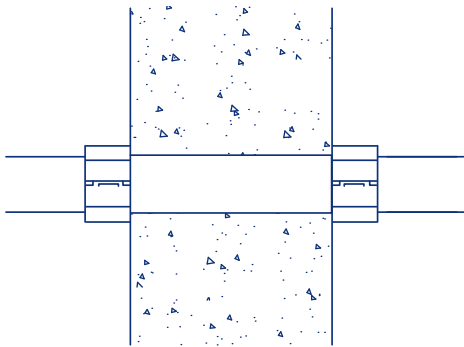

Passage through the wall — external location

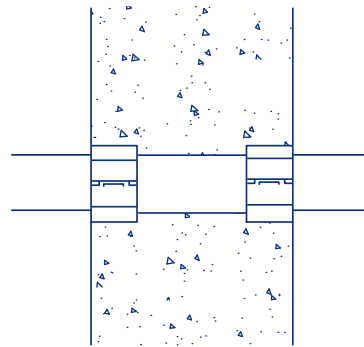

Passage through the wall — internal location

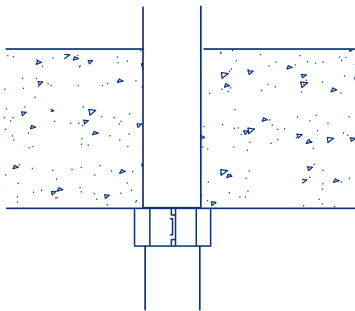

Passage through the floor — external location

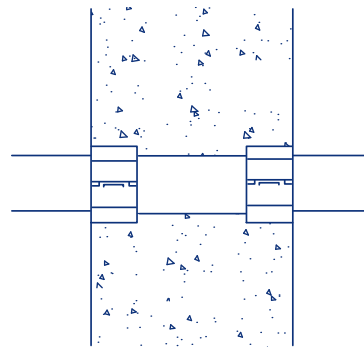

Passage through the floor — internal location

It is important to only use firestop sleeves that have been manufactured in accordance with local fire safety regulations and have the approval of the project supervisor. These sleeves are designed for specific pipe base materials, diameters, wall thicknesses, and building structures that are specified in the regulations.



Please note: For each method and product used, it is crucial to follow the manufacturer's guidelines and specifications when designing, planning and applying the fire collars and wraps.

TRANSPORT, STORAGE AND HANDLING

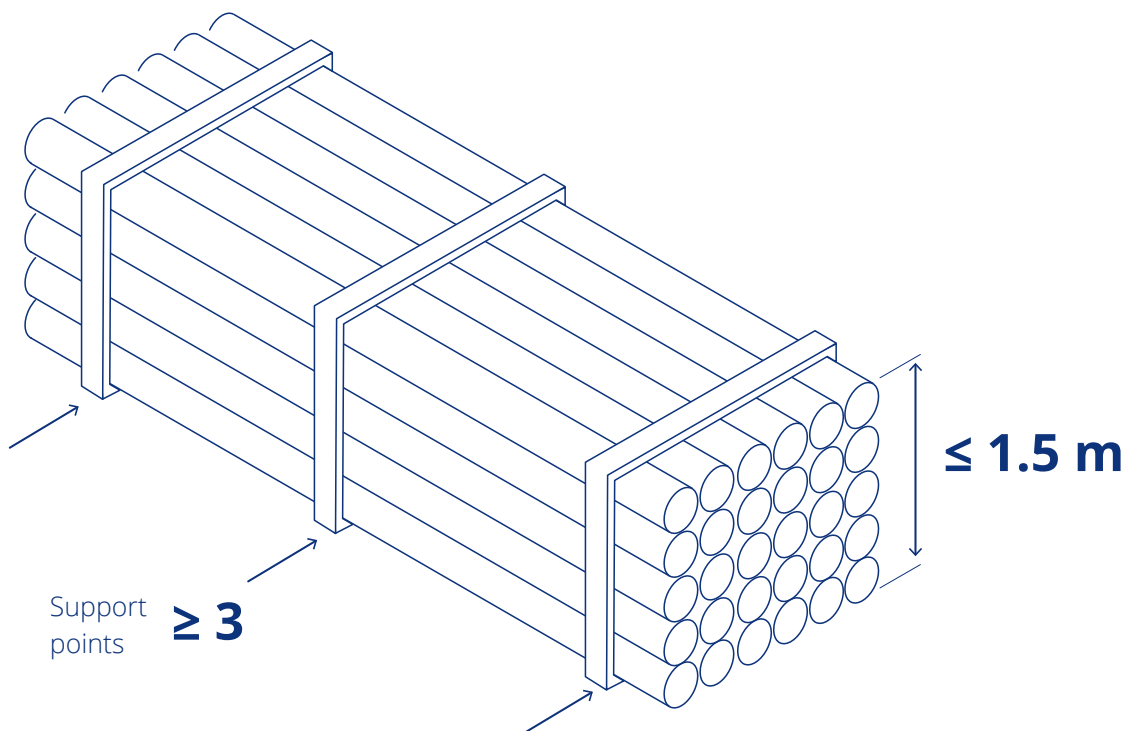

The functionality of PIPELIFE siphonic drainage systems is not only influenced by the installation process but also by the storage and transportation practices that precede this. **Therefore, we recommend that these steps are followed during storage, handling and transportation:**

- Pipes must only be transported and stored in unit loads that have been prepared by the manufacturer.
- When transporting and storing individual pipes, it is best to use flat surfaces. If this is not an option, it is important to ensure there is at least a 3-point support system in place.
- When opening the unit loads, it is important to handle the products with care and avoid dragging them over hard surfaces.
- It is important to ensure that no soil or sand contaminates the pipe ends during handling.
- Use the correct equipment to ensure safe and proper loading. It is also important to avoid bending straight pipes during the loading process.
- To prevent point load damage, avoid placing heavy objects on pipes during loading and storage.
- Pipe stacks must not exceed a height of 1.5 meters.
- When storing multiple packages of pipes on top of one another, the packaging frames must be placed on top of one another.
- If pipes are stored in the open for extended periods of time, cover them with an awning curtain or place them in covered storage facilities for protection.

SYSTEM DESIGN SERVICE

DIMENSIONING OF HYDRAULICS

Based on information provided by the architect and building services engineer, PIPELIFE offers a hydraulic dimensioning service to identify the correct system parameters for your building.

PIPELIFE will provide all necessary documentation once dimensioning has been completed, including:

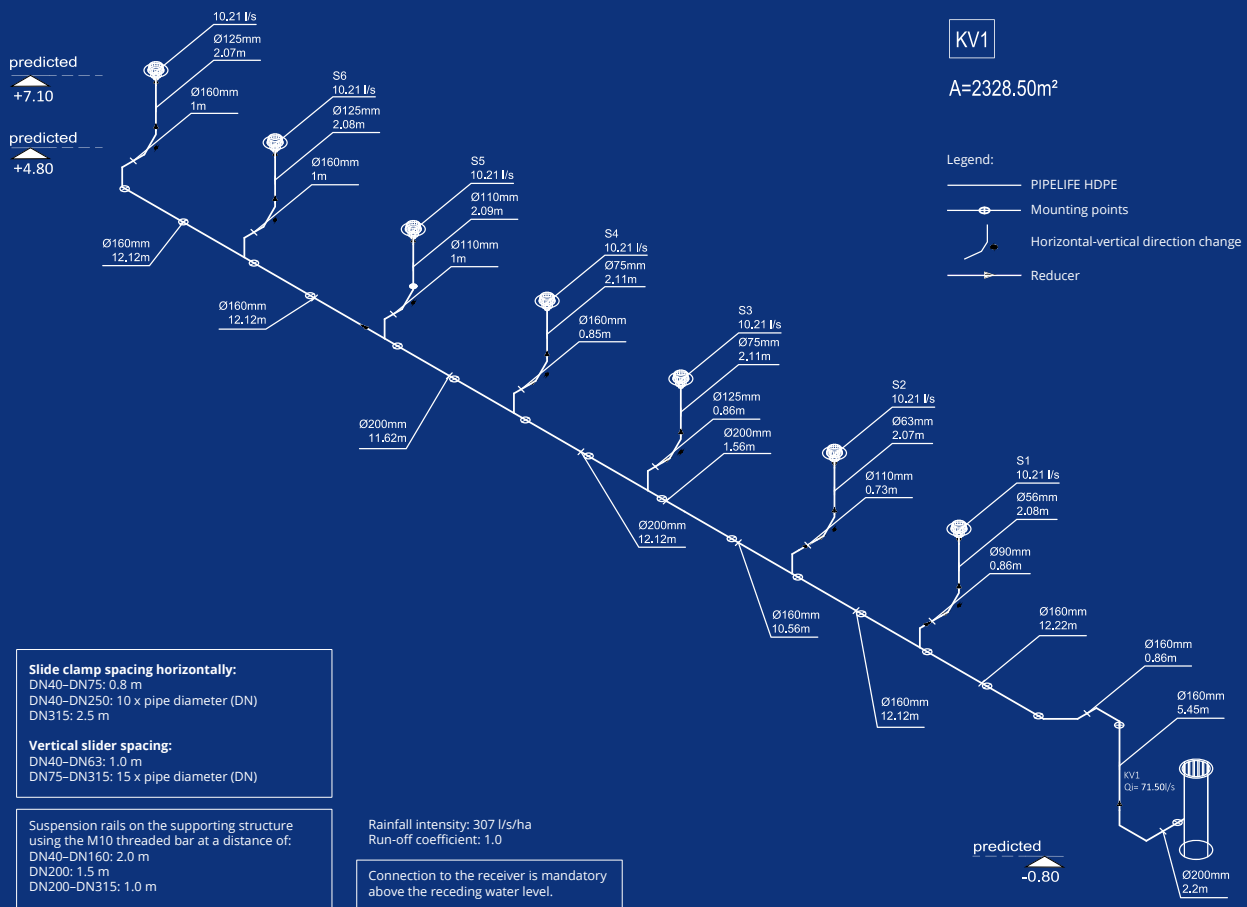

+ An isometric drawing of the system, indicating pipe diameters and mounting points

+ Quantities and specifications of required elements (pipes, fasteners, fixing devices, etc.)

+ An overall cost breakdown

Deviations from the original documentation (e.g., changes in pipe lengths or diameters) must have written consent from PIPELIFE before being implemented. The system's technical acceptance procedure must take place with the participation of the PIPELIFE specialists. PIPELIFE will provide a guarantee for the siphonic drainage system based on the project supervisor's declaration.

BIM

PIPELIFE also offers a comprehensive BIM library of system assets for expert users to develop custom setups themselves.

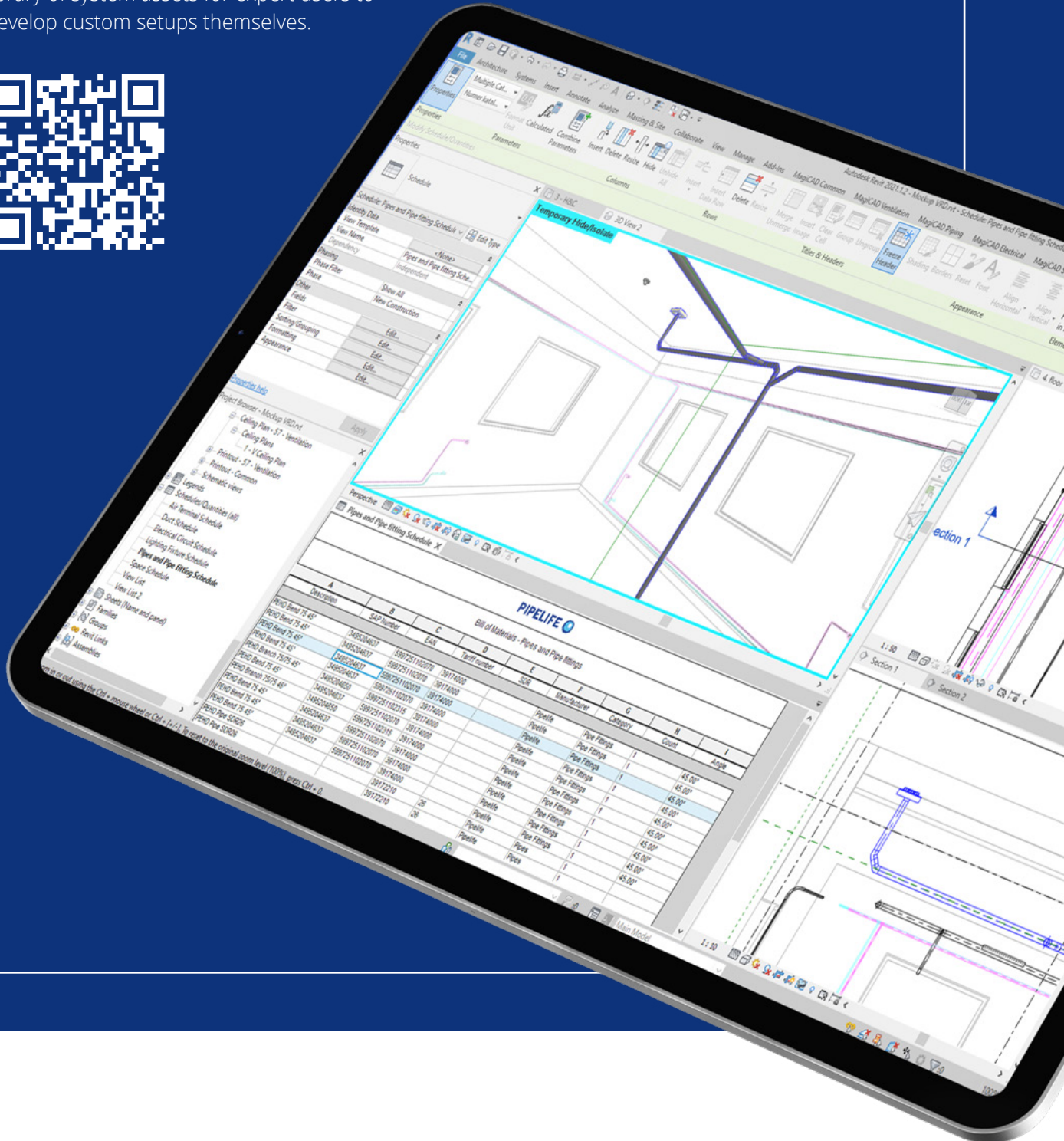



The contents and information contained in this brochure are intended for general marketing purposes only and shall not be relied upon by any person as complete or accurate. In particular, this brochure cannot replace proper expert advice on the characteristics of the products, their usage, suitability for any intended purpose, or the proper processing method. All contributions and illustrations in this brochure are subject to copyright. Unless explicitly otherwise stated, the repetition of content is not permitted. The use of photocopies from this brochure is for private and non-commercial use only. Any duplication or distribution for professional purposes is strictly forbidden. Non-Liability: PIPELIFE has established this brochure to the best of its knowledge. PIPELIFE cannot accept any liability suffered or incurred by any person resulting from or in connection with any reliance on the content of or the information contained in this brochure. This limitation applies to all loss or damage of any kind, including but not limited to direct or indirect damages, consequential or punitive damages, frustrated expenses, lost profit or loss of business.

Date issued: 10.10.2023

PIPELIFE International GmbH, Wienerbergerplatz 1, 1100 Wien
T +43 1 602 2030 0, E info@pipelife.com, pipelife.com

PIPELIFE 
always part of your life